



**GIDDYUP
POWER**
EV CHARGING

PLUG-IN ELECTRIC VEHICLE COLLABORATIVE (PEV)

APRIL 18, 2023

INTRODUCING THE SACRT POWER INN CHARGING HUB

- Public-Private Partnership between SacRT and GiddyUp
- Transportation hub accessible to multi-family dwelling tenants, fleets without charging capabilities, rideshares, etc. – all are welcome!
- Unique site design to accommodate all vehicles types
- Clients can reserve and schedule use time
- Ten (10) 175kw DC Fast Chargers (CCS & Chademo)
- Anticipated opening June 2023

SACRT DCFC HUB AT POWER INN STATION



SACRT LOT DIAGRAM

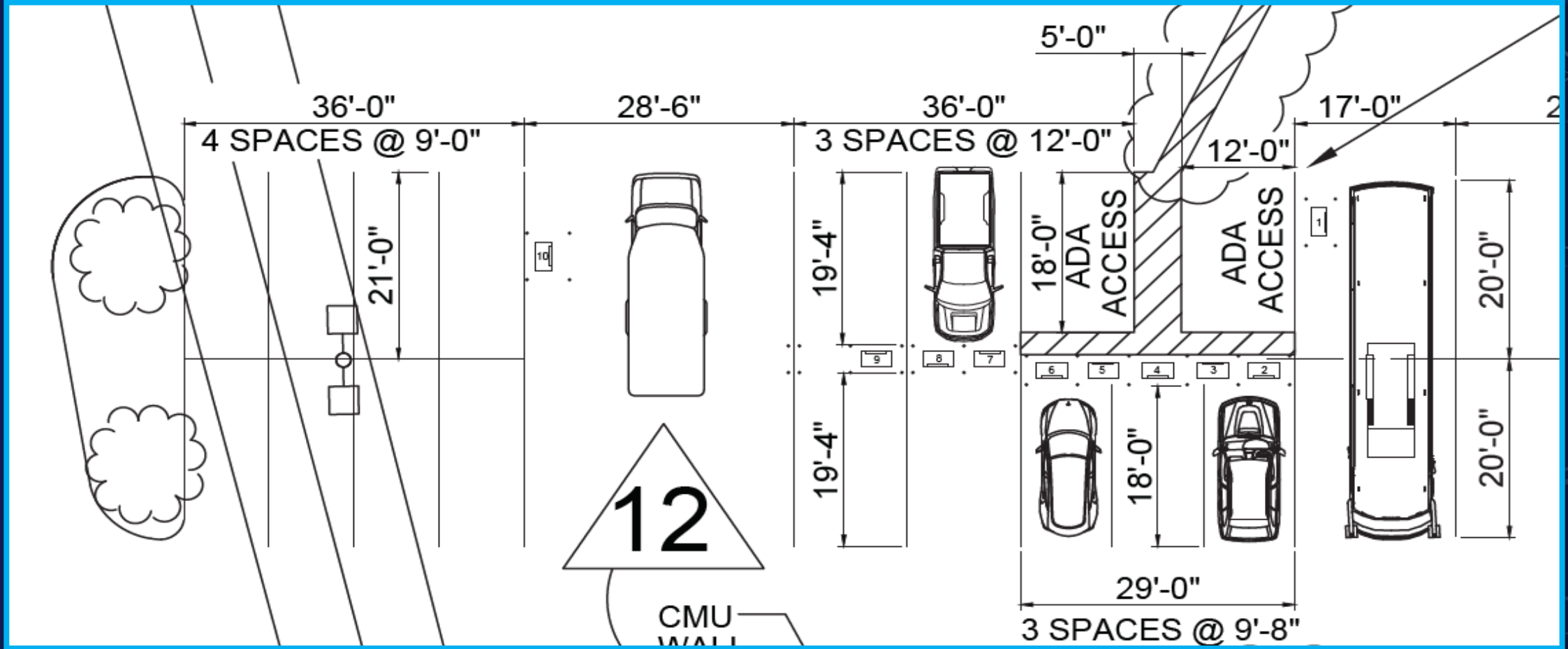



GiddyUp is proud to announce the launch of its newest public/private charging site located at the Sacramento Regional Transit District's Power Inn Road light rail station.

Attention Fleet Operators

GiddyUp has more benefits for your business!

Are you looking for a Sacramento based location to charge light, medium and/or heavy duty EVs?



- Ten (10) Level 3 (175 kW) chargers – most vehicles charged within 20 minutes
- Offering Diverse Vehicle Access including ADA (2), 40' (1) space and 28.5' wide (2) spaces
- 24/7 Access
- Appointments Available
- Camera Monitored
- Membership Options
- Fleet Pricing Programs
- Online Use Reports

Contact Us fleet@giddyuppower.com
(415) 289-5520
giddyuppower.com



SACRT POWER INN STATION CHARGING HUB UPDATE

- [Insert pics before presentation]
- Open to the public 24/7
- Capable of fast-charging any EV (15 minutes = 150 miles of vehicle range)
- Accommodates many vehicle types – cars, trucks, buses, etc.
- Sacramento County has expressed interest in using Power Inn Rd DCFC's for EV fleet
- Thank You Chris Flores, Tim Taylor & Gina O'Neal for all the support

MEETING REGIONAL, STATE AND FEDERAL GOALS

Forbes WHEELS

California Governor Gavin Newsom Signs Executive Order Phasing Out Gasoline Vehicles By 2035

Andrew Wender
Forbes Staff

California Regulation Sets Course for Emission-Free Buses by 2040

The rule, which requires the adoption of electric or hydrogen-fueled buses, has received mixed reviews from transit agencies.

CNBC

MARKETS BUSINESS INVESTING TECH POLITICS CNBC TV WATCHLIST PRO 6



Markets Are Moving Fast. Stay Ahead of the Curve. EXPLORE OUR LATEST INSIGHTS

AUTOS

Biden plans to replace government fleet with electric vehicles

PUBLISHED MON, JAN 25 2021-5:38 PM EST | UPDATED TUE, JAN 26 2021-8:58 AM EST

Michael Wayland
@MIKEWAYLAND



California to Require Half of All Heavy Trucks Sold by 2035 to Be Electric

The state is setting strict limits to try to eliminate carbon dioxide emissions from transportation, the sector of the American economy that generates the most greenhouse gases.

ars TECHNICA

BIZ & IT TECH SCIENCE POLICY CARS GAMING & CULTURE STOR

California set to ban all heavy diesel trucks and vans by 2045

BYE, SOOT—

Heavy-duty trucks are responsible for 70% of vehicle air pollution in the state.



COMMUNITY, ECONOMIC DEVELOPMENT AND LOCAL ENGAGEMENT OPPORTUNITIES

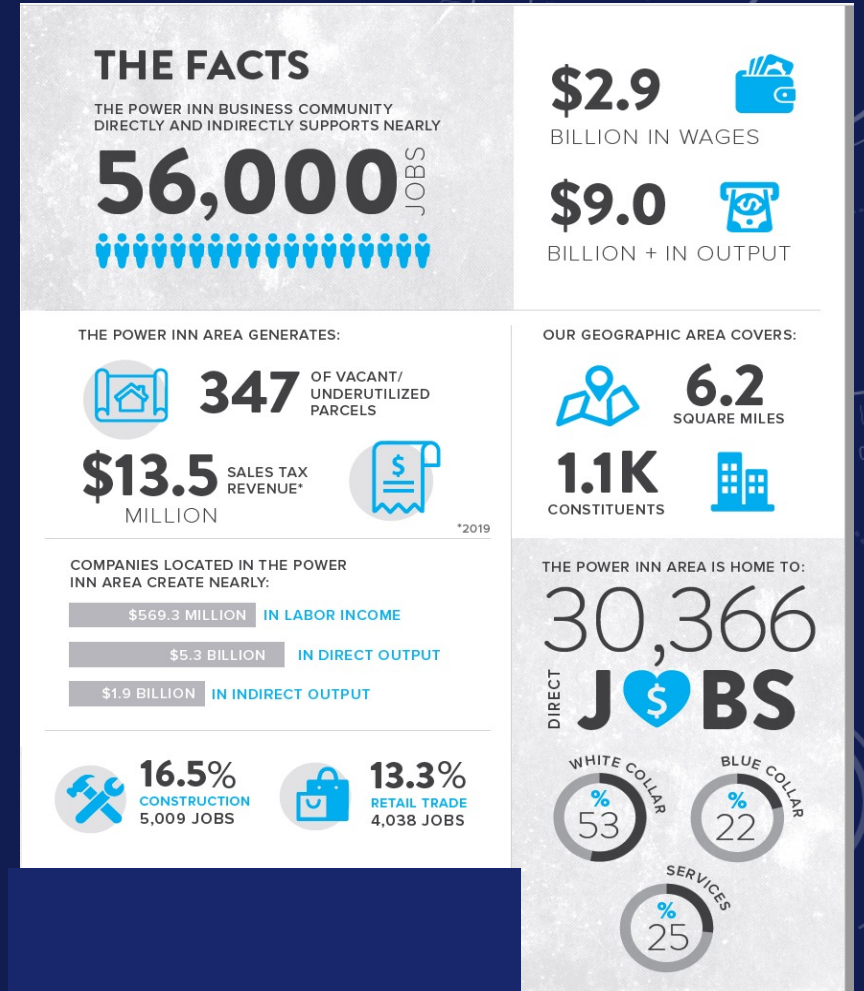

THE GIDDYUP SOLUTION

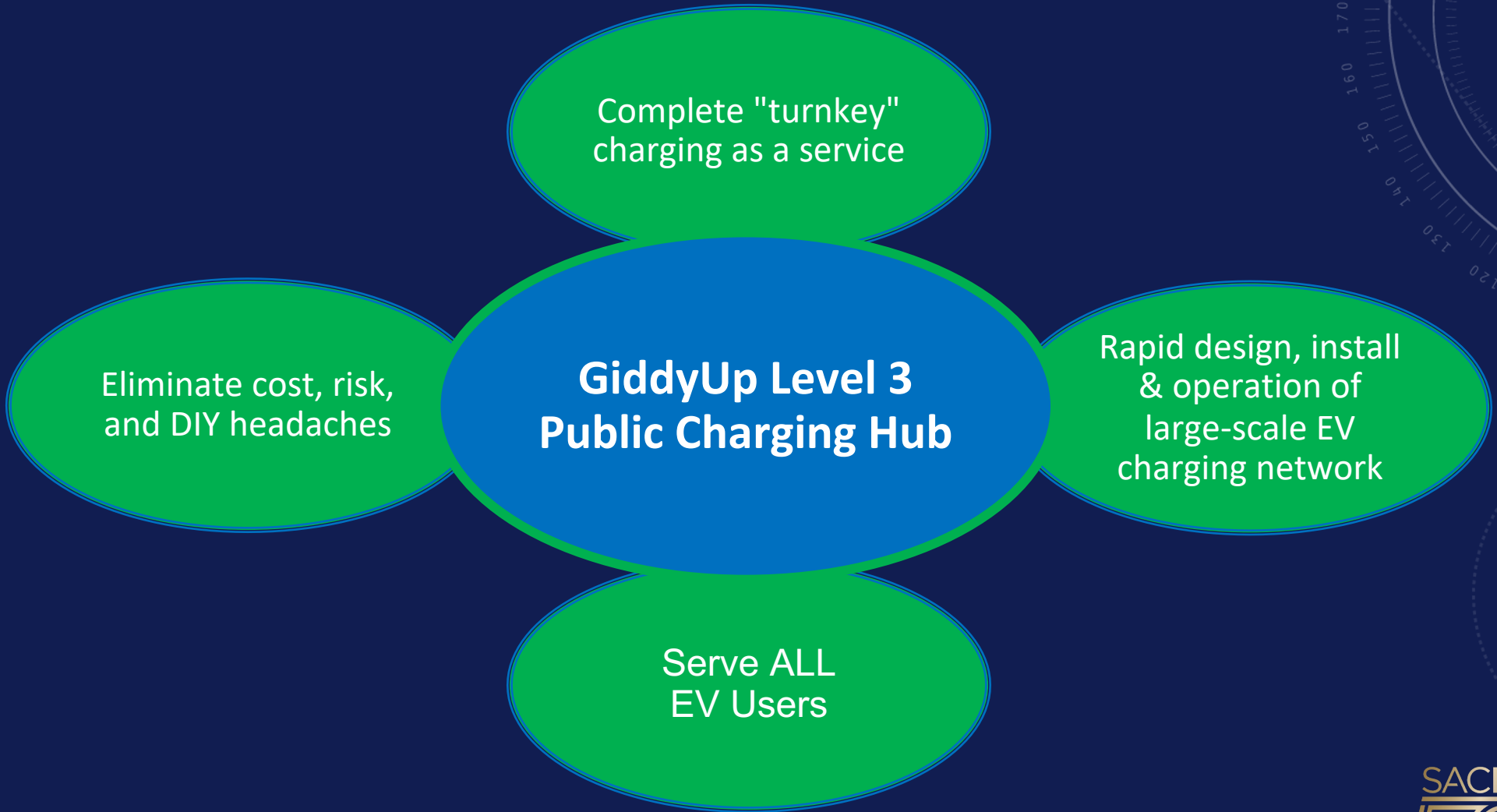

GIDDYUP'S NEXT SACRAMENTO CHARGING HUB COMING TO A LOCATION NEAR YOU



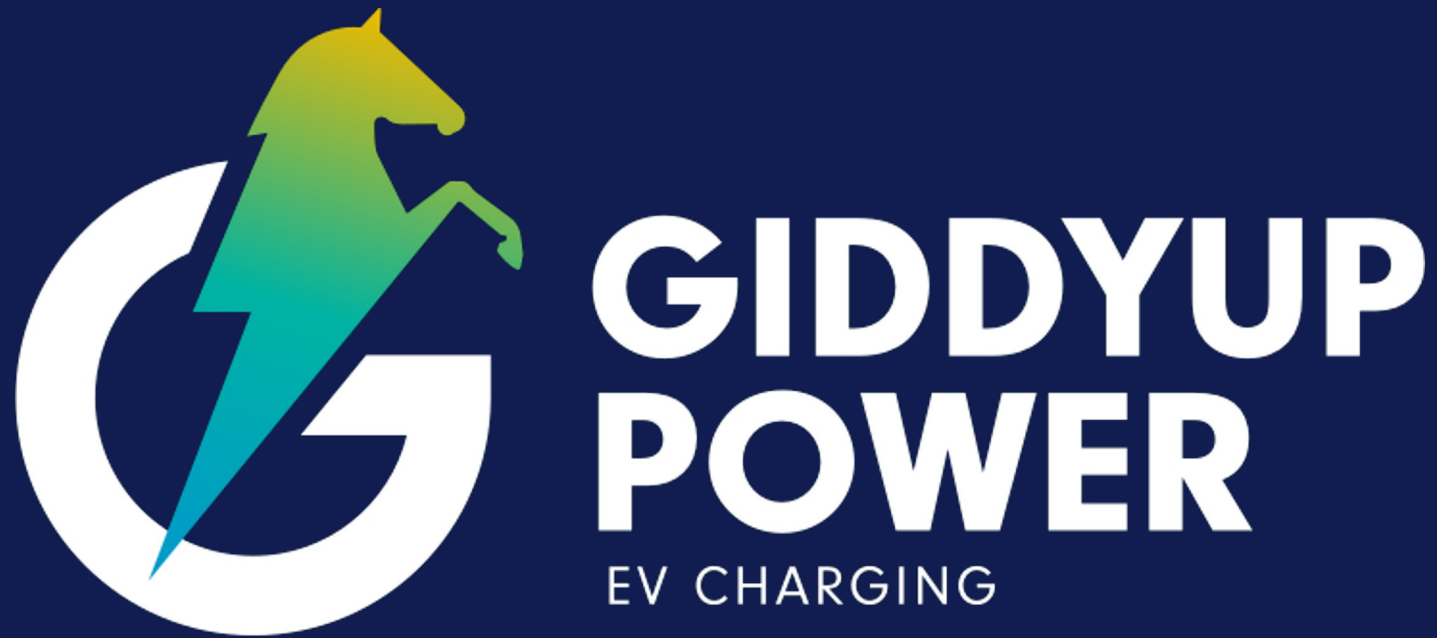

“CHARGING SACRAMENTO!”